

## HELICAL BEVEL BACKSTOP SELECTION AND INSTALLATION GUIDE

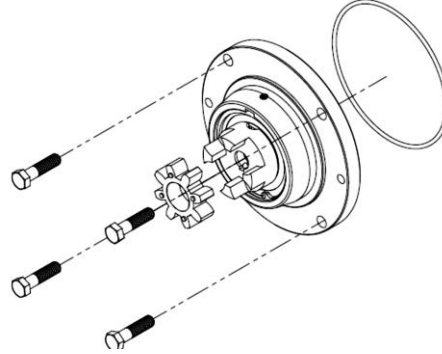

Rotation of output shaft must be specified at time of ordering as viewed from the output shaft end (see diagram below). Under normal running conditions, no maintenance will be required.

Operating temperature range: -40°F (-40°C) to 212°F (+100°C). Peaks up to 248°F (+120°C) are acceptable for short periods.

**WARNING:** DO NOT exceed backstop maximum holding torque of 25lb-ft (34 Nm) for 56C/140TC size backstop and 88lb-ft (119Nm) for 180TC size backstop.

**WARNING:** DO NOT exceed backstop maximum rated over speed of 3000 RPM.

**WARNING:** DO NOT remove motor or backstop until all driven equipment is fully secured and made safe. Failure to do so may result in bodily injury and/or damage to equipment.

Written authorization from D&F Equipment is required to operate or use the backstop in man lift or people moving devices.

CW	Free rotation in Clockwise direction.	Locked rotation in Counterclockwise rotation.
CCW	Free rotation in Counterclockwise direction.	Locked rotation in Clockwise rotation

### HELICAL BEVEL BACKSTOP SELECTION

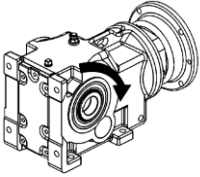
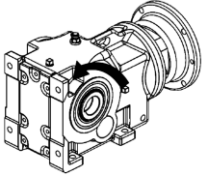
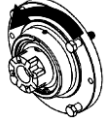
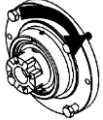
CW Output Shaft Rotation		CCW Output Shaft Rotation	
			
Backstop Rotation		Backstop Rotation	
			
NEMA Frame	Backstop Part Number	NEMA Frame	Backstop Part Number
56C	37.KR0456BSLH	56C	37.KR0456BSRH
140TC	37.KR04140BSLH	140TC	37.KR04140BSRH
180TC	37.KR06180BSLH	180TC	37.KR06180BSRH

## BACKSTOP INSTALLATION

The backstop is assembled at the factory and labeled with a tamper detection mark. Disassembly of the backstop for any reason will void any and all warranties.

The backstop is supplied with the proper mounting hardware which includes the mounting bolts, coupling spider, and O-ring which is to be mounted between the motor C-face and the backstop.

Check to make sure the backstop rotates in the proper direction for the application referring to the previous section.

Refer to the diagram below for assembly.

1. Install backstop on motor shaft orientating the backstop until the word "TOP" is aligned at the 12 o'clock position. Make sure the motor shaft key is positioned properly and the mating faces of the motor and backstop are flush. The use of an approved anti-seize compound is recommended to facilitate motor removal at a future date if required.
2. Tighten item (1) set screw to lock motor shaft key in place.
3. Install item (2) coupling spider and align with input coupling half of the reducer. Install motor/backstop combination making sure the mating surfaces of the reducer input flange and backstop are flush.
4. Install item (3) mounting bolts and tighten accordingly.
5. Removal of backstop is reverse of installation.

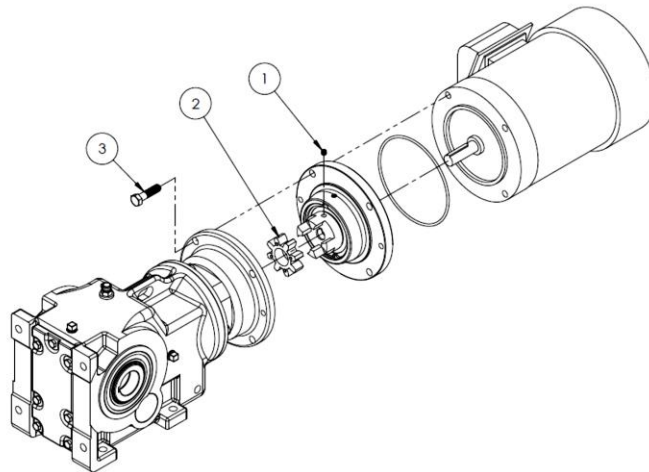

**WARNING:** **DO NOT** remove motor or backstop until all driven equipment is fully secured and made safe. Failure to do so may result in bodily injury and/or damage to equipment.